

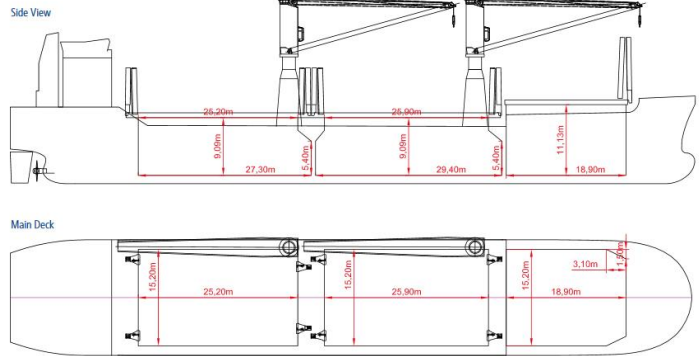

MV BREB COURTESY



SHIPS BASICS

Name	BREB COURTESY
Built	2009
Classification	DNV GL
Typ	Geared Multi-purpose dry cargo ship
IMO-No.	9421130
Flag	Portuguese
Port of Registry	Madeira
Call Sign	CQIR3

DIMENSIONS AND MAIN DATA

Tonnage	abt. 5.630 GT / 2.883 NT
Summer dwt	abt. 7.801 mt
Length o.a.	abt. 108,20 m
Length b.p.	abt. 103,90
Beam	abt. 18,20 m
Draft max.	abt. 7,031 m
Speed	abt. 10 kts on abt 11,0 mts in ballast 11.4 mts in loaded condition IFO380 cst

TECHNICAL SPECIFICATION

Main Engine	MaK 6 M32C, 3000 KW
Aux Engine	MAN Diesel engine, 390 KW
Emergency Generator	130 kW
Bowthruster	280 kW

TANK CAPACITY

IFO	abt. 418,3 cbm
MGO	abt. 67,8 cbm
Ballastwater	abt. 2.512,7 cbm
Freshwater	abt. 69,1 cbm

HATCH AND HOLD

Number	3 Holds
Hold dimensions	Hold 1: abt. 18,90m x 15,20m x 11,20m Hold 2: abt. 29,40m x 15,20m x 9,10m Hold 3: abt. 27,30m x 15,20m x 9,10m
Hold capacity	10.291,50 cbm / abt. 363.441 cbf Hold 1: 2.772,00 cbm / 97.892,30 cbft Hold 2: 3.903,10 cbm / 137.836,70 cbft Hold 3: 3.616,40 cbm / 127.712,00 cbft
Number	3 Hatches
Hatch cover dimensions	Hatch 1: abt. 17,90m x 15,20m x 0,75m Hatch 2: abt. 26,40m x 15,20m x 0,75m Hatch 3: abt. 25,70m x 15,20m x 0,75m
Hatch type	MacGregor folding type

OTHERS

Cargo Gear	2 x MacGregor 36mt at 26m outreach
Grabs	2 x Peiner-grabs with 8,0cbm 8 sec opening / 11-14 sec closing of grab
Tank top strength	15 mt per sqm
Timber Stanchions	60 aluminium stanchions
Cement Holes	10 cement-holes, Ø 540mm

COMMUNICATION

Phone	+49 1704786142
E-Mail	master@duhnen.briese-fleet.com charter@duhnen.briese-fleet.com